

YAMAHA



SOUND CARD SW60XG



OWNER'S MANUAL

GENERAL
MIDI
XG

FCC ID : A6RSW60

This device complies with Part 15 of the FCC rules. Operation is subject to the following two conditions: (1) This device may not cause harmful interference, and (2) this device must accept any interference received, including interference that may cause undesired operation.

FCC INFORMATION (U.S.A)

1. IMPORTANT NOTICE: DO NOT MODIFY THIS UNIT!

This product, when installed as indicated in the instructions contained in this manual, meets FCC requirements. Modifications not expressly approved by Yamaha may void your authority, granted by the FCC, to use the product.

2. IMPORTANT: When connecting this product to accessories and/or another product use only high quality shielded cables.

Cable/s supplied with this product MUST be used. Follow all installation instructions. Failure to follow instructions could void your FCC authorization to use this product in the USA.

3. NOTE: This product has been tested and found to comply with the requirements listed in FCC Regulations, Part 15 for Class "B" digital devices. Compliance with these requirements provides a reasonable level of assurance that your use of this product in a residential environment will not result in harmful interference with other electronic devices. This equipment generates/uses radio frequencies and, if not installed and used according to the instructions found in the user's manual, may cause interference harmful to the operation of other electronic devices. Compliance with FCC regulations does not guarantee that interference will not occur in all installations. If this product is found to be the source of interference, which can be determined by turning the unit "OFF" and "ON", please try to eliminate the problem by using one of the following measures :

Relocate either this product or the device that is being affected by the interference.

Utilize power outlets that are on different branch (circuit breaker or fuse) circuits or install AC line filter/s.

In the case of radio or TV interference, relocate/reorient the antenna.

If the antenna lead-in is 300 ohm ribbon lead, change the lead-in to co-axial type cable.

If these corrective measures do not produce satisfactory results, please contact the your local retailer authorized to distribute this type of product

If you can not locate the appropriate retailer, please contact Yamaha Corporation of America, Electronic Service Division, 6600 Orangethorpe Ave, Buena Park, CA 90620

The above statements apply ONLY to those products distributed by Yamaha Corporation of America or its subsidiaries.

PRECAUTIONS

- The sound card contains no user-serviceable parts, so never touch the inside area of the circuit board or tamper with the electronic circuitry in any way. Doing so may result in electrical shock or damage to the sound card.
- When holding the sound card, do not touch the inside area of the circuit board or apply excessive pressure to the card, and be sure to protect the card from contact with water or other liquids.
- Before installing the sound card in the computer, unplug the power connector of your computer.
- Before touching the sound card, be sure to touch a metal surface to discharge any static electricity from your body.
- Before connecting the computer to other devices, turn off the power switches of all devices.
- Do not expose the sound card to direct sunlight, excessive humidity, high temperatures, excessive dust or strong vibrations.
- The sound card contains digital circuitry and may cause interference if placed too close to radio or television receivers.
- It is possible that computer malfunctions or operator actions might destroy data that was created with the included application software. We recommend that you back up all important data onto floppy disks. Yamaha is not responsible for data loss through computer malfunctions or operator actions.

Yamaha cannot be held responsible for damage caused by improper care and use of the sound card and software.

SPECIAL NOTICES

- The software and this owner's manual are the exclusive copyrights of Yamaha Corporation.
- Copying of the software or reproduction of this manual in whole or in part by any means is expressly forbidden without the written consent of the manufacturer.
- Use of the software and this manual is governed by the license agreement which the purchaser fully agrees to upon breaking the seal of the software packaging. (Please read carefully the Software Licensing Agreement at the end of this manual before installing the application.)
- Yamaha makes no representations or warranties with regard to the use of the software and documentation and cannot be held responsible for the results of the use of this manual and the software.
- Windows and MS-DOS are the registered trademarks of Microsoft® Corporation.
- IBM PC/AT™ is a trademark of IBM® Corporation.
- The company names and product names in this Owner's Manual are the trademarks or registered trademarks of their respective companies.

NOTICE: The screen displays as illustrated in this owner's manual are for instructional purposes, and may appear somewhat different from the screens which appear on your computer. Future upgrades of application and system software and any changes in specifications and functions will be announced separately.

INTRODUCTION

Thank you for purchasing the SW60XG — a high quality sound card with hundreds of musical instrument voices and a variety of high quality digital effects.

This owner's manual covers installation of the SW60XG sound card as well as the installation of the applications and SW60XG driver.

To ensure proper installation and use of the hardware and software, please read this owner's manual carefully, and be sure to keep it in a safe place for future reference.

MAIN FEATURES

AWM WAVE TABLE

- Contains 676 Normal voices and 21 Drum voices (sets) generated by Advanced Wave Memory 2 (AWM2) tone generation system with the maximum 32-note polyphony.
Allows you to play and perfect the files compatible with General MIDI (GM) and XG format.

KARAOKE & EFFECTS

- Features versatile DSP effects, 11 Reverb effects, 11 Chorus effects and 44 Variation effects. A/D inputs allows you to mix external inputs with the internal voices and effects. The EffectGearII, an Windows application, lets you use a variety of stunning effects, change the pitch of a song, or reduce the volume of the main vocal from a song playing on a CD (for karaoke sing-along). The EFFECTCON, a DOS application, lets you control the sounds for the GM compatible DOS games.

NOTE You can NOT directly select and control the voices and effects from the SW60XG, since neither knob nor button is furnished on top of the SW60XG.

However, you can select and control them by transmitting the System Exclusive Messages, such as XG System On*, to the SW60XG. In this case you need an appropriate sequencing software which can configures and edits the System Exclusive Messages.

As to the MIDI Data Format (including System Exclusive Messages), Normal and Drum Voice Lists, and Effect Type List, please refer to the SW60XG Folder found in the included floppy disk.

* XG System On (F0 43 1n 4C 00 00 7E 00 F7)
TG300B Reset (F0 41 1n 42 12 40 00 7F 00 41 F7)
n=Device Number

TABLE OF CONTENTS

Package Contents & Minimum System Requirements	2
SW60XG Setup	3
1. Names and Functions	3
2. Sound Card Installation	4
3. Application Software Installation	6
SW60XG Application Software	10
EffectGearII	10
EFFECTCON	11
Troubleshooting	12
Specifications	13

WINDOWS OPERATION

This owner's manual assumes that you are already familiar with basic Windows operation. If you are not, please refer to the owner's manual which came with your Windows software before using the SW60XG hardware and software.

PACKAGE CONTENTS & MINIMUM SYSTEM REQUIREMENTS

PACKAGE CONTENTS

The SW60XG package includes the items listed below, so before beginning, please take a moment to make sure you have everything you need. (If something is missing, please contact your authorized Yamaha dealer.)

- Sound card SW60XG
- Floppy Disk x 1: Install Disk
- Owner's Manual x 1: Yamaha SW60XG Owner's Manual
- User registration card

MINIMUM SYSTEM REQUIREMENTS

Proper use of the Yamaha SW60XG requires at minimum the following:

COMPUTER HARDWARE

● Memory

Requires an 80386SX/33MHz or higher internal CPU with a minimum of 8MB RAM.

● Hard Disk

Proper software installation and running the SW60XG requires at least 3MB of free space on your hard disk.

● Floppy Disk Drive

To install the application software, and to save and load user data.

● Mouse

Requires a Windows 3.1 or Windows 95 compatible mouse.

● Expansion slot (ISA16 bits)

Required for installation of the SW60XG sound card.

DOS

Requires MS DOS Ver. 5.0 or higher to run Windows 3.1.

Windows

Requires Windows 3.1 or higher.

OTHERS

Additional hardware as listed below will permit maximum enjoyment of the SW60XG.

CD-ROM Drive

Connecting CD-ROM's output with SW60XG's CD IN lets you control the effects for the sound from CD-ROM.

POWERED SPEAKERS

You can enjoy powerful and dynamic stereo sound by connecting powered speakers and other stereo audio components to the OUTPUT jack.

SW60XG SETUP

1. NAMES AND FUNCTIONS

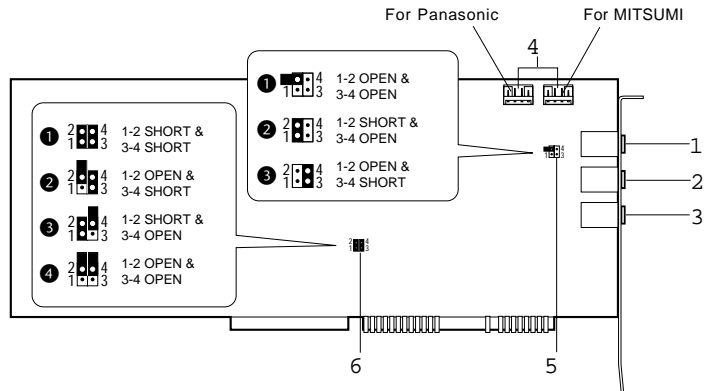

- 1 **MIC IN jack:** Mono mini plug type jack allows connection to the separately available dynamic microphone (Monaural). MIC TYPE jumper (see below) allows use of a 2-lead or 3-lead condenser type microphone.
- 2 **LINE IN jack:** Stereo mini plug type jack allows input of line-level stereo signals from external audio devices.
- 3 **OUTPUT jack:** Stereo mini plug type jack outputs standard line-level stereo signals. Allows connection to powered speakers or the inputs of a recording mixer and other audio devices including headphones.
- 4 **CD IN connector:** Allows stereo input of line-level signals from a CD-ROM built in the computer. (Panasonic or MITSUMI)
- 5 **MIC type jumper:** Lets you select the type of amplifier configurations depending on the type of microphone connected. (3-lead condenser or dynamic microphone; 2-lead condenser microphone.)
 - ① 1-2 Open/3-4 Open: dynamic microphone.
 - ② 1-2 Short/3-4 Open: 2-lead condenser microphone.
 - ③ 1-2 Open/3-4 Short: 3-lead condenser microphone.

* Default position is 1: dynamic microphone.
- 6 **MIDI Port Address jumper:** Allows to select the appropriate MIDI Port Address for sending the MIDI signals from the ISA bus to the SW60XG. You may need to change the MIDI Port Address (default address) if some conflict problem occurs. Please consider which address to use before the sound card installation.
 - ① 1-2 Short/3-4 Short: 300
 - ② 1-2 Open/3-4 Short: 310
 - ③ 1-2 Short/3-4 Open: 320
 - ④ 1-2 Open/3-4 Open: 330

* Default position is 1: 300.

CAUTION If you change the MIDI Port Address position here, you are required to select the same Address for the Driver. (See page 9)

CONNECTIONS

The following diagram shows how to connect the various devices.

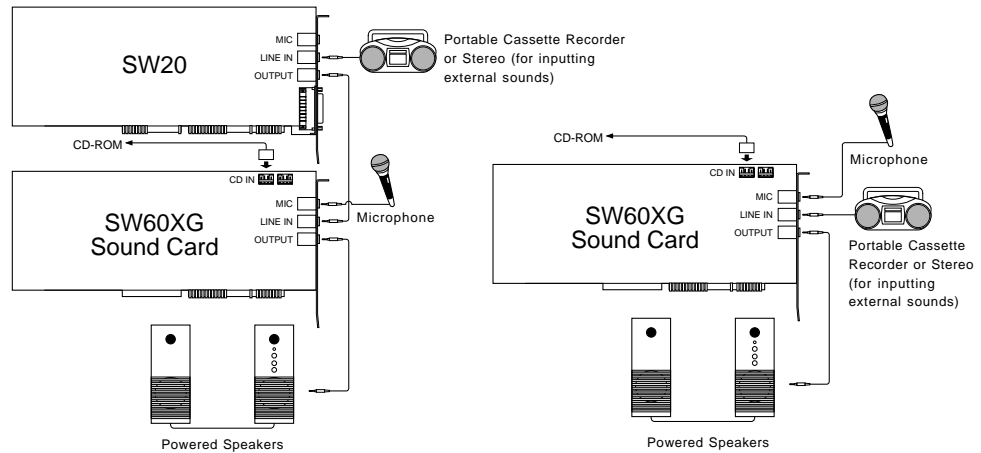

CAUTION Before making connections, be sure to UNPLUG THE POWER SUPPLY CORDS OF ALL DEVICES. After making connections, switch on the power of each device in the following order: External inputting devices first, then the computer, then external audio devices. (NOTE: MAKE SURE TO TURN DOWN THE VOLUME LEVELS OF THE EXTERNAL AUDIO DEVICES BEFORE TURNING THEM ON.) When turning off the power of each device, simply reverse the process.

CAUTION Improper connection of microphone and other external devices may cause ear injury or damage to hardware.

NOTE There are various types of audio in and out jacks, so make sure to select the proper cables and adaptors according to your respective devices.

4

2. SOUND CARD INSTALLATION

The sound card fits into an ISA bus expansion slot in your computer.

1. Turn off the computer and unplug its AC power cord.

CAUTION Do not attempt to install your sound card while the computer is plugged in. This can cause irreparable damage to the sound card, and may pose a serious shock hazard!

2. Remove the top cover of the computer.

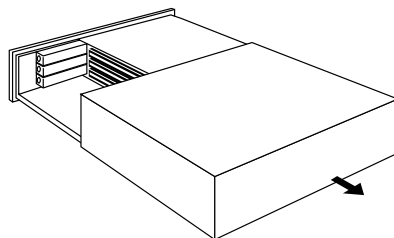

NOTE The proper method for removing the top cover varies depending on the type of computer you use, so please see your computer's owner's manual for the proper procedure. Wear gloves to avoid cuts by any sharp edges on the cover.

3. To remove the expansion slot cover, simply unscrew it and take it away.

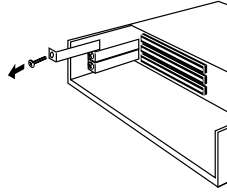

NOTE Be sure to keep the expansion slot cover in a safe place for future use.

4. Carefully remove the sound card from the anti-static bag.

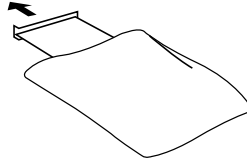

CAUTION Before touching the sound card, first touch a metal surface to discharge any static electricity in your body; such static electricity can cause serious damage to your SW60XG. Also do not touch the inside surfaces of your sound card in order to prevent possible interference with or damage to the circuitry.

5. Hold the sound card with two hands as shown, and slowly and steadily insert it into the expansion slot, making sure to properly line up the connectors in the card with those in the slot. To prevent breaking or damaging the sound card during installation, do not use excessive force when inserting the sound card into the expansion slot.

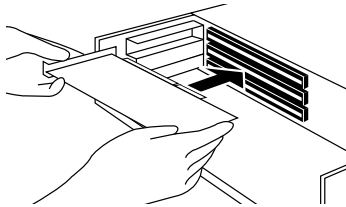

6. Use the screw from step 3, above, to secure the sound card to the computer.

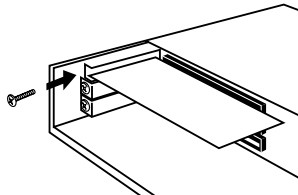

7. Finally, carefully replace the top cover of your computer.

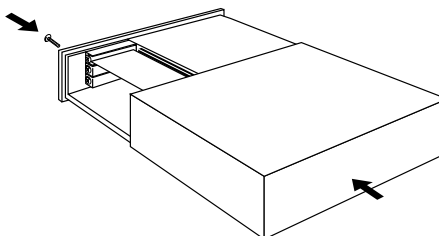

NOTE To remove the sound card, simply reverse the above process.

3. SOFTWARE INSTALLATION

To use the SW60XG, the SW60XG driver and the application software should be installed in your computer properly.

CAUTION If your computer is run by Windows 3.1, the installation program will overwrite the contents of the MIDI Mapper. The installation program also overwrites the AUTOEXEC.BAT, SYSTEM.INI and CONTROL.INI files. If you don't want to lose any existing data, please save them before you install the SW60XG application software.

Installation Procedure for Windows 3.1

1. Insert Install Disk into your floppy disk drive.
2. Click [File] in the Menu Bar of the Program Manager window, then click [Run].



Run Dialog Box will appear.



3. In the command line text box, type the name of the drive where you inserted Install Disk and file name "SETUP".



NOTE This manual assumes that your floppy disk drive is the A drive. If your drive is different, then choose the drive specified for your computer.

Type A:SETUP, then press the <ENTER> key.

When Install Disk is verified, the following Setup screen will appear.

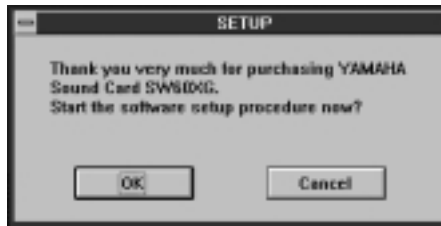

4. Click [OK] to proceed to next procedure.
The drive/directory, which the SW60XG is to be installed into, will appear.
5. Verify the drive/directory names and click [OK].

NOTE The default setting installs the software to the C drive and _SW60XG directory.
If you want to use a different drive/directory, type in the name of the different drive/directory.

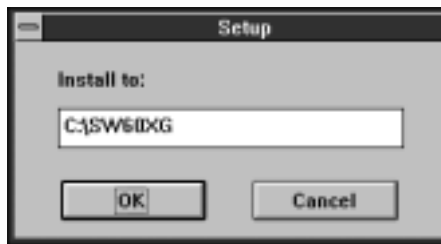

The following window appears and installation begins.

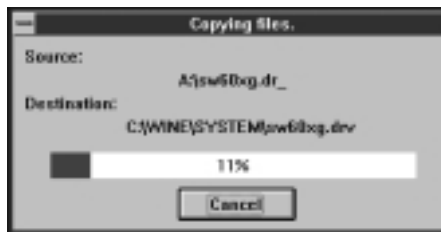

The above window will show the progress of the installation for Windows on a graph. When the installation is completed, the following screen will appear.

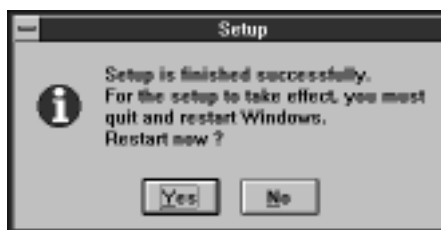

6. Press <Y> to restart your computer.

Installation Procedure for Windows 95

1. Double click the [Control Panel] icon in My Computer. Control Panel window appears.



2. Double click the [Add/Remove Programs] icon in the Control Panel. Add/Remove Programs Properties will appear.



3. Click [Install].
Install Program from Floppy Disk Or CD-ROM will appear.

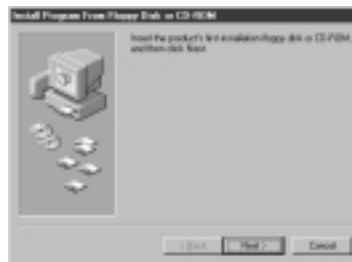

4. Insert Install Disk into your floppy disk drive, and click [Next].
Run Installation Program Dialog Box will appear.

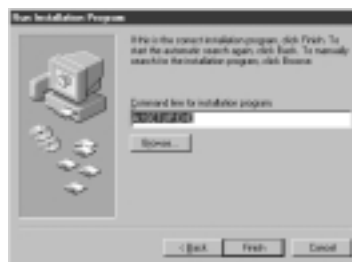

5. Verify the command line and click the [Finish].
The Setup screen will appear.

The following procedures are the same as the ones, the number 4 through 6, of the Windows 3.1 installation.

Additions to the AUTOEXEC.BAT, SYSTEM.INI and CONTROL.INI files

The SW60XG software program will automatically add the following lines to these files.

AUTOEXEC.BAT * " " indicates a space.

```
rem--SW60XG installer wrote. Do not modify the following_line--
C:\SW60XG\efcon_/type:1_/line:100_/mic:100_/midi:100_/vcl:0
rem --
```

*If you add the above lines to the AUTOEXEC.BAT when you make the start-up disk for DOS games, you can automatically add effects to the game sounds.

SYSTEM.INI

```
[drivers]
midixx=sw60xg.drv

[SW60XG.DRV]
port=300
```

* xx=An appropriate value.

CONTROL.INI

```
[drivers.desc]
sw60xg.drv=Yamaha SW60XG.Drv

[Userinstable.drivers]
midixx=sw60XG.drv
```

ABOUT THE DRIVER

In order for Windows to work with MIDI, a driver (and MIDI mapper for Windows 3.1) is required. The Yamaha SW60XG software installation procedure automatically places the Yamaha SW60XG Driver in the Control Panel and the "SW60XG" MIDI map into the MIDI Mapper.

If the other application software has already used the MIDI Port Address 300, you are required to select the address other than 300 in the SW60XG Driver Setup. (You are also required to change the MIDI Port Address jumper setting to the same number as the address you have selected here. See page 3 for the MIDI Port Address jumper setting.)

Setting up the MIDI Port Address (SW60XG Driver) for Windows 3.1

1. Double click the [Control Panel] icon in the Main group.
The Driver Setup Dialog Box appears.
2. Click to select the [Yamaha SW60XG Driver].
3. Click the [Setup] to open the Yamaha SW60XG Driver Setup.

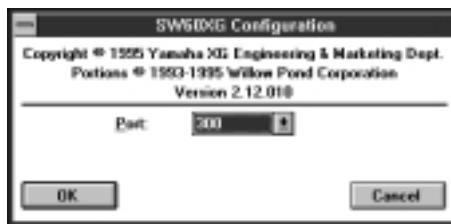

4. Change the MIDI Port Address as required.

In a similar way, you can change the MIDI Port Address in the Advanced setup in the Multimedia Properties (Control Panel) for Windows 95.

CAUTION Be sure to change the MIDI Port Address jumper setting to the same number as the address you have selected here. See page 3 for the MIDI Port Address jumper setting.

SW60XG APPLICATION SOFTWARE

SW60XG offers you to use two types of effect controllers, the one for Windows and the other for DOS; EffectGearII and EFFECTCON respectively.

EffectGearII

The EffectGearII lets you apply various types of effects to the signal input by a microphone, the line-level input signal from CD-ROM audio playback. You can also change the pitch of a song, or reduce the volume of the main vocal from a song playing on a CD (for karaoke sing-along).

Startup Procedure

Double click on the [EffectGearII] icon and the EffectGearII application will start.

Names and Functions

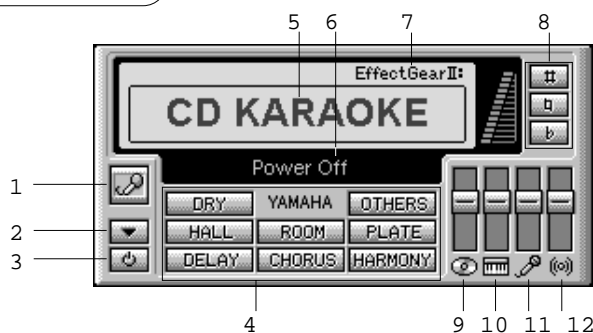

- 1 VOICE CANCEL button:** Click this button to reduce the volume level of the vocal from a song from CD audio playback for karaoke sing-along accompaniment. The voice cancel function may not be effective depending on the type of effect applied.
- 2 MINIMIZE button:** Click this button to resize the EffectGearII window to icon size.
- 3 POWER OFF button:** Click this button to exit EffectGearII.
- 4 EFFECT MENU buttons:** Click one of these buttons to select an effect. Click the [Others] button to display the effect type list. You can assign the effect you frequently use to the [Others] button.
- 5 EFFECT display box:** The name of the currently selected effect type will appear in the display box. You can also display the effect type list by double clicking this box.
- 6 ONE-LINE HELP box:** The name of the button/function at which the mouse pointer is currently located will be displayed.
- 7 Always on Top:** Click here to open the Always on Top dialog box. When enabled, the EffectGearII window or icon is always shown on top of any other application.
- 8 PITCH SHIFT buttons:** Click these buttons to increase or decrease the pitch of sound by a semitone (100 cents), which will be displayed on the LED next to the buttons. Original sound pitch is represented by center position = 0; each click will move the LED display ± 100 cents at a time. The buttons may disappear and you can not control the pitch depending on the type of effect applied.

- 9 **LINE/CD IN fader:** Lets you adjust the line/CD input level.
The fader may disappear and you can not control the input level depending on the type of effect applied.
- 10 **MIDI fader:** Lets you adjust MIDI input level.
You cannot directly control the effect which is applied to the sounds generated through MIDI.
- 11 **MIC fader:** Lets you adjust the microphone input level.
- 12 **EFFECT DEPTH fader:** Lets you adjust the effect depth.
When you click the [DRY] button to select the (original) dry sound, the fader will disappear and you can not control the depth.

NOTE When moving the Effect Depth fader close to the maximum position, howling may happen depending on the type of effect you select.

The effects which create Karaoke sing-along environment are as follows.

CD KARAOKE: Reduces the volume of the main vocal from a song playing on an audio CD, and lets you sing along the accompaniments. Reverb will be applied to the sound input by Mic. The pitch of the accompaniments can be adjusted.

MIDI KARAOKE: Lets you sing along the songs (accompaniments) using the commercially available MIDI files. Echo will be applied to the sound input by Mic. The pitch of the accompaniments can be adjusted.

EFFECTCON

The EFFECTCON lets you apply high quality effects to the signal input by a microphone, the line-level input signal on the DOS command line.

Startup Procedure

Start EFFECTCON in the SW60XG directory.

[KEY OPERATION] * " " indicates a space.

CD \SW60XG + <ENTER>
EFCON + <ENTER>

A list of commands will appear on screen.

```

C:\>CD SW60XG
C:\SW60XG>EFCON
EFCON - SW60XG Control Utility Version 1.00
Copyright© (c)1995 YAMAHA Corp. All rights reserved.
Usage : efcon [Batch commands]
1 /quiet Verbose on/off
2 /type:[x] Type No. x:0-3 0:Dry / 1:Rev / 2:Cho / 3:Rev+Cho
3 /line:[x] Line/CD Volume x:0-127
4 /mic:[x] Mic Volume x:0-127
5 /midi:[x] MIDI Volume x:0-127
6 /rev:[x] Reverb Depth x:0-127
7 /cho:[x] Chorus Depth x:0-127
8 /vcl:[x] Voice Cancel x:0|1 0:off / 1:on
9 /detect Detect SW60XG
10 /test Test SW60XG
C:\SW60XG>

```

Command Names and Functions

- 1 QUIET: Suppresses configuration messages usually displayed whenever you execute a command.
[KEY OPERATION] EFCON_/QUIET + <ENTER>
- 2 TYPE: Changes the effect type. Valid values are 0~3.
[KEY OPERATION] EFCON_/TYPE:x + <ENTER>
* x = Type number (0 = Dry, 1 = Reverb, 2 = Chorus, 3 = Reverb+Chorus)
- 3 LINE: Sets the input level from LINE/CD IN.
[KEY OPERATION] EFCON_/LINE:y + <ENTER>
* y = Volume (0 - 127)
- 4 MIC: Sets the input level from MIC IN.
[KEY OPERATION] EFCON_/MIC:y + <ENTER>
* y = Volume (0 - 127)
- 5 MIDI: Sets the input level through MIDI.
[KEY OPERATION] EFCON_/MIDI:y + <ENTER>
* y = Volume (0 - 127)
- 6 REV: Sets the reverb depth.
[KEY OPERATION] EFCON_/REV:y + <ENTER>
* y = Volume (0 - 127)
- 7 CHO: Sets the chorus depth.
[KEY OPERATION] EFCON_/CHO:y + <ENTER>
* y = Volume (0 - 127)
- 8 VCL: Executes Voice Cancel. Execute this command to reduce the volume level of the vocal from a song from CD audio playback for karaoke sing-along accompaniment.
[KEY OPERATION] EFCON_/VCL:z + <ENTER>
* z = Off/On status (0 = Off, 1 = On)
- 9 DETECT: Allows you to verify the status of four MIDI Port Addresses.
[KEY OPERATION] EFCON_/DETECT + <ENTER>
- 10 TEST: Allows you to test the contents of the SW60XG hardware.
[KEY OPERATION] EFCON_/TEST + <ENTER>

TROUBLESHOOTING

Windows will not start.

- The sound card may not be inserted properly into the expansion slot. Check it or insert the sound card into another expansion slot and try again.

MIDI (internal synthesizer) does not sound.

- YAMAHA SW60XG Driver may not be selected as the MIDI output port.
- Check if EffectGearII's input fader is set to minimum, thus preventing sound output.

Changing the effect type or starting up the EffectGearII during MIDI song playback forcibly resets the voices to Piano.

- Changing the effect from Dry (No effect) to the others or vice versa during MIDI song playback resets and initializes all the parameters of the tone generator. In this case all the voices excepting the Channel 10 (drum part) will be reset to Piano voice (Grand Piano). The same problem will occur when starting up the EffectGearII.

SPECIFICATIONS

Minimum System Requirements

Computer (PC/AT compatible)	CPU: 80386/33MHz or higher Memory: 8MB of system memory or higher 16-bit ISA internal slot
Monitor	Color or gray scale VGA or Super VGA compatible
External Devices	Mouse, hard disk and audio speakers or headphones
OS	DOS Ver 5.0 or higher; Windows 3.1 or higher

Synthesizer Module

Yamaha SWP00	Number of Voices: 676 Normal Voices, 21 drum Voices (sets) Polyphony: 32-note (AWM 2 wave table) Multi-timbral Capacity: 16 voices simultaneously Wave ROM 4MB
---------------------	---

Compatibility

Sound Module Mode	GM System Level 1 XG TG300B
-------------------	-----------------------------------

Effects

Yamaha SWP00	Reverb(11), Chorus(11), Variation(44)
Yamaha KP (YSS205)	Voice Cancel

Terminals

OUTPUT	Stereo mini jack
LINE IN	Stereo mini jack
MIC IN	Mono mini jack
CD-ROM Connector	Panasonic, MITSUMI

Other Specifications

Dimensions (W x D x H)	107 x 224 x 22mm (4-1/4" x 8-7/8" x 7/8")
Weight	130g (4-2/3 oz.)

Specifications subject to change without notice.

SOFTWARE LICENSING AGREEMENT

The following is a legal agreement between you, the end user, and Yamaha Corporation ("Yamaha"). The enclosed Yamaha software program is licensed by Yamaha to the original purchaser for use only on the terms set forth herein. Please read this licensing agreement with care. Opening this package indicates that you accept all terms outlined herein. If you do not agree to the terms, return this package unopened to Yamaha for a full refund.

1. GRANT OF LICENSE AND COPYRIGHT

Yamaha grants you, the original purchaser, the right to use one copy of the enclosed software program and data ("SOFTWARE") on a single-user computer system. You may not use it on more than one computer or computer terminal.

The SOFTWARE is owned by Yamaha and is protected by Japanese copyright laws and all applicable international treaty provisions. You are entitled to claim ownership of the media in which the SOFTWARE is included. Therefore, you must treat the SOFTWARE like any other copyrighted materials.

2. RESTRICTIONS

The SOFTWARE program is copyrighted. You may not engage in reverse engineering or reproduction of the SOFTWARE by other conceivable methods.

You may not reproduce, modify, change, rent, lease, resell, or distribute the SOFTWARE in whole or in part, or create derivative works from the SOFTWARE. You may not transmit or network the SOFTWARE with other computers.

You may transfer ownership of the SOFTWARE and the accompanying written materials on a permanent basis provided that you retain no copies and the recipient agrees to the terms of the licensing agreement.

3. TERMINATION

The licensing condition of the software program becomes effective on the day that you receive the SOFTWARE. If any one of the copyright laws or clauses of the licensing conditions is violated, the licensing agreement shall be terminated automatically without notice from Yamaha. In this case, you must destroy the licensed SOFTWARE and its copies immediately.

4. PRODUCT WARRANTY

Yamaha warrants to the original purchaser that if the SOFTWARE, when used in normal conditions, will not perform the functions described in the manual provided by Yamaha, the sole remedy will be that Yamaha will replace any magnetic media which proves defective in materials or workmanship on an exchange basis without charge. Except as expressly set forth above, the SOFTWARE is provided "as is," and no other warranties, either expressed or implied, are made with respect to this software, including, without limitation the implied warranties of merchantability and fitness for a particular purpose.

5. LIMITED LIABILITY

Your sole remedies and Yamaha's entire liability are as set forth above. In no event will Yamaha be liable to you or any other person for any damages, including without limitation any incidental or consequential damages, expenses, lost profits, lost savings or other damages arising out of the use or inability to use such SOFTWARE even if Yamaha or an authorized dealer has been advised of the possibility of such damages, or for any claim by any other party.

6. GENERAL

This license agreement shall be interpreted according to and governed by Japanese laws.

YAMAHA
YAMAHA CORPORATION

M.D.G., EMI Division, ©Yamaha Corporation 1995